



PIATTAFORMA PER LAVORO AEREO AUTOCARRATA

TRUCK-MOUNTED AERIAL LIFT WORK PLATFORM

HUBARBEITSBÜHNE AUF LKW



PNT200HE

isoli@isoli.com | www.isoli.com

Marc THISSEN
0495 123 764
www.vibam.com
marc.thissen@vibam.com



DIMENSIONI / OVERALL DIMENSION / GESAMTABMESSUNGEN [mm]



DIAGRAMMA DI LAVORO / WORKING DIAGRAM / ARBEITSDIAGRAMM [m]



[KIT: IVECO]

CARATTERISTICHE TECNICHE / TECHNICAL FEATURES / TECHNISCHE EIGENSCHAFTEN

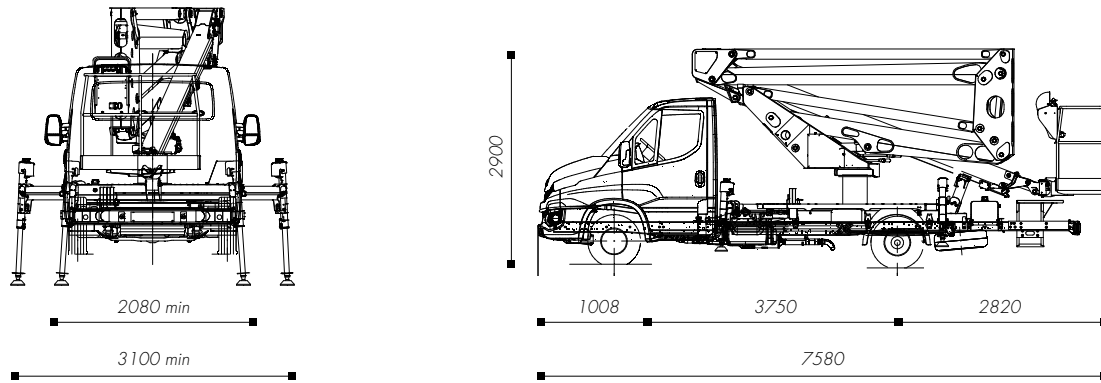
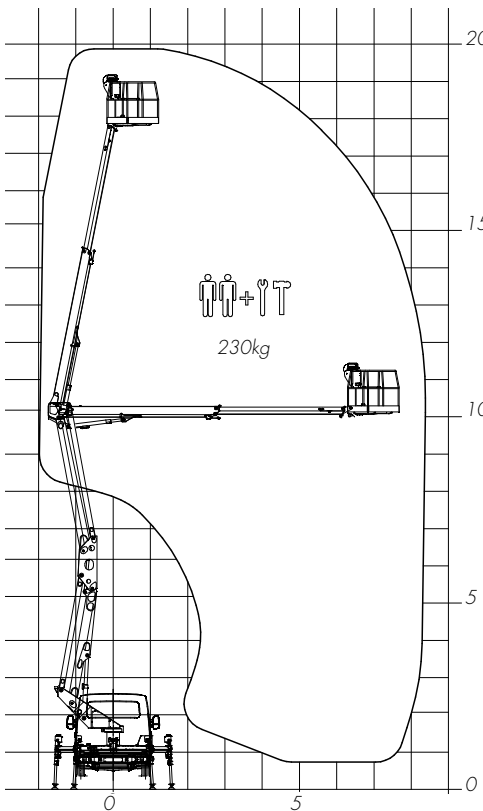
	Altezza max. di lavoro Max. working height Max. Arbeitshöhe	19,9 m
	Sbraccio max. di lavoro Max. working boom extension Max. Reichweite	8,4 m
	Portata Capacity Traglast	230 Kg
	N. operatori N. operators Anzahl Personen	2
	Velocità max. vento Max. wind speed Max. Windgeschwindigkeit	12,5 m/s
	Braccio di lavoro doppio Working boom Hubarm	Pantografo + Braccio telescopico a 2 sezioni Double pantograph + 2 Section telescopic arm Pantograph-Gelenkteleskoparm, 2-stufig
	Rotazione sovrastruttura Upperstructure rotation Drehung Oberwagen	400°
	Cesta Basket Arbeitskorb	Alluminio 1400x710x1100 mm Aluminium 1400x710x1100 mm Alluminium 1400x710x1100 mm
	Rotazione cesta Basket rotation Korbsschwenkung	Idraulica 90° dx + 90° sx Hydraulic 90° right + 90° left Hydraulisch 90° rechts und 90° links
	Livellamento cesta Basket leveling Kornivellierung	Idraulico Hydraulic Hydraulisch
	Stabilizzatori Outriggers Abstützungen	Verticale HE-H sagoma Vertical stabilisation HE-H in folded position Vertikale Stabilisierung HE-H in gefalteter Position
	Comandi Controls Steuerungen	Elettroidraulici Electro-hydraulic Elektrohydraulisch
	Installazione minima Minimum installation Min. Gesamtgewicht	3500 Kg

Marc THISSEN
0495 123 764
www.vibam.com
marc.thissen@vibam.com