



PIATTAFORMA PER LAVORO AEREO AUTOCARRATA

TRUCK-MOUNTED AERIAL LIFT WORK PLATFORM

HUBARBEITSBÜHNE AUF LKW



PNT220NLX

isoli@isoli.com | www.isoli.com

Marc THISSEN
0495 123 764
www.vibam.com
marc.thissen@vibam.com



DIMENSIONI / OVERALL DIMENSION / GESAMTABMESSUNGEN [mm]



DIAGRAMMA DI LAVORO / WORKING DIAGRAM / ARBEITSDIAGRAMM [m]

A= 80kg B= 120kg C= 200kg D= 250kg

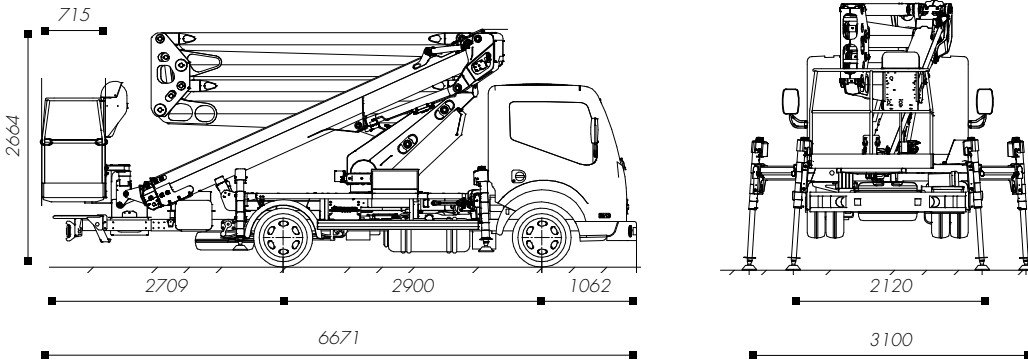
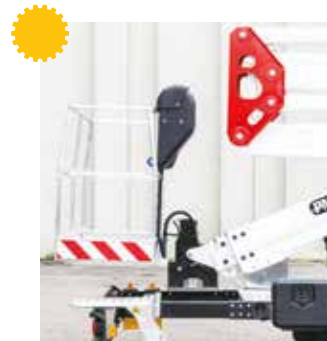
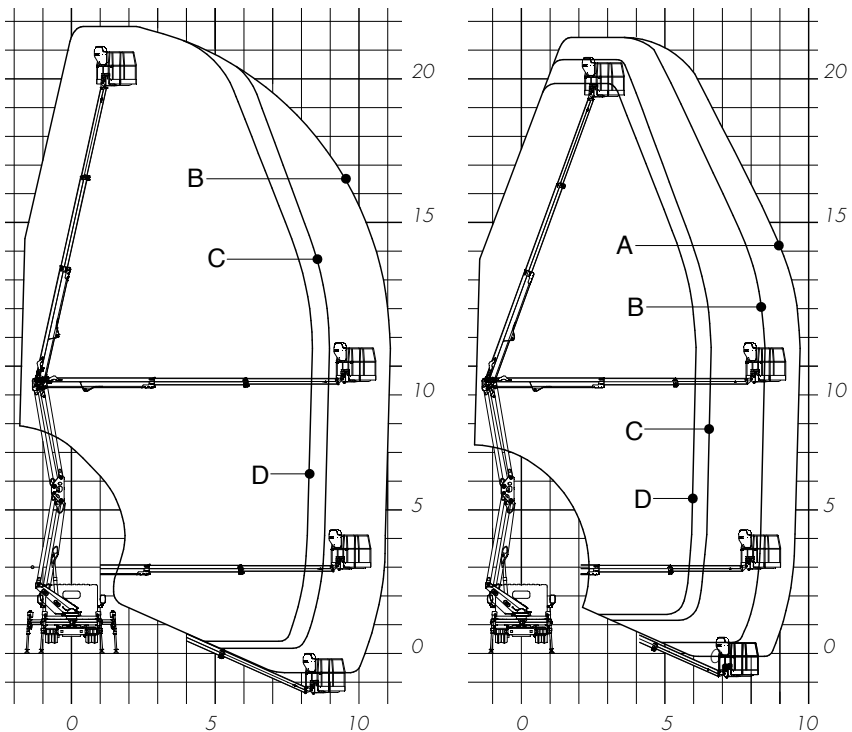

CARATTERISTICHE TECNICHE / TECHNICAL FEATURES / TECHNISCHE EIGENSCHAFTEN

	Altezza max. di lavoro Max. working height Max. Arbeitshöhe	21,8 m
	Sbraccio max. di lavoro Max. working boom extension Max. Reichweite	11,2 m
	Portata Capacity Traglast	250 Kg
	N. operatori N. operators Anzahl Personen	2
	Altezza piano calpestio Walk-on surface height Korbodenhöhe	19,90 m
	Rotazione sovrastruttura Upperstructure rotation Drehung Oberwagen	600°
	Cesta Basket Arbeitskorb	Alluminio 1400x710x1115 mm Aluminium 1400x710x1115 mm Alluminium 1400x710x1115 mm
	Rotazione cestello Basket rotation Korbrotation	90° dx/sx 90° R.-H./L.-H. 90° Rechts/Links
	Comandi Controls Steuerungen	Elettroidraulici Electro-hydraulic with can bus control panel Elektrohydraulisch
	Stabilizzatori Outriggers Abstützungen	H-H

Marc THISSEN
0495 123 764
www.vibam.com
marc.thissen@vibam.com